

# USER MANUAL

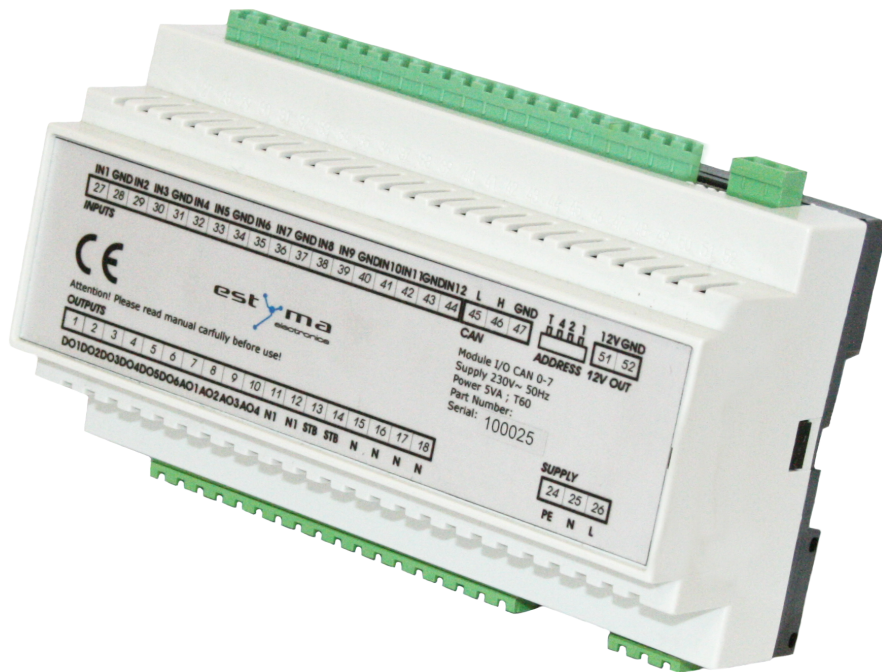

## EXPANSION MODULE CAN I/O MC-1

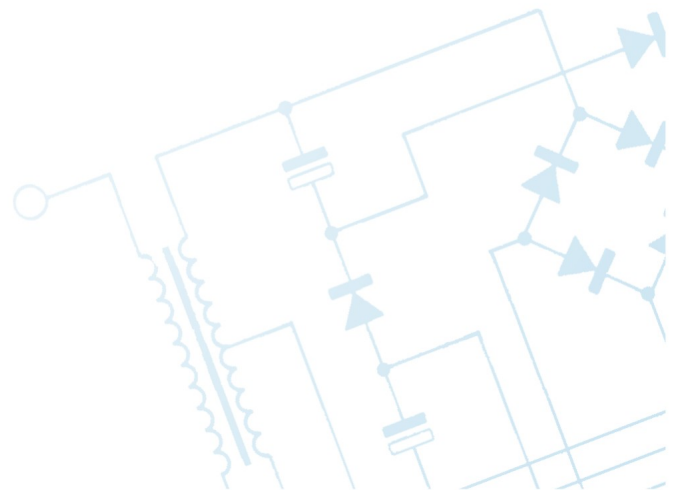



## Index

<b>1 General information</b>	<b>4</b>
<b>1.1 Introduction</b>	<b>4</b>
<b>1.2 Contents</b>	<b>4</b>
<b>1.3 Safety precautions</b>	<b>5</b>
<b>1.4 Disposal of old equipment</b>	<b>6</b>
<b>2 Connecting to the system</b>	<b>7</b>
<b>2.1 General requirements</b>	<b>7</b>
<b>2.2 Location</b>	<b>7</b>
<b>2.3 Assembly</b>	<b>8</b>
<b>2.4 Connecting</b>	<b>9</b>
2.4.1 Power.....	10
2.4.2 CAN.....	10
2.4.3 Output power +12V.....	11
<b>2.5 Modules addressing</b>	<b>11</b>
<b>3 Circuits diagrams</b>	<b>13</b>
<b>3.1 System 1</b>	<b>13</b>
<b>3.2 System 2</b>	<b>15</b>
<b>3.3 System 3</b>	<b>17</b>
<b>3.4 System 4</b>	<b>19</b>
<b>3.5 System 5</b>	<b>21</b>
<b>4 Description of input and output modules</b>	<b>23</b>
<b>4.1 Module 0 - circuits CH 2-4</b>	<b>23</b>
<b>4.2 Module 1 - circuits CH 5-7</b>	<b>24</b>
<b>4.3 Module 2 – circuits CH 8-10</b>	<b>25</b>
<b>4.4 Module 3 – circuits CH 11-13</b>	<b>26</b>
<b>4.5 Module 4 – circuits CH 14-16</b>	<b>27</b>
<b>4.6 Module 5 – circuits HW 2, buffer, solar collectors</b>	<b>28</b>

# 1 General information

---

## 1 General information

*Thank you for choosing our product and congratulations on a good decision. We will be grateful for comments concerning the unit's performance.*

*ESTYMA electronics  
Team*

### 1.1 Introduction

CAN I/O MC-1 is a expansion module to the new line of boiler controls IGNEO. The modules communicate with the main controller using well known for reliability, widely used in automotive, CAN bus.

Modular design allows for adjustment automatics to the heating system requirements.

By using expansion modules is possible handling the following elements of the heating system:

- to 16 heating circuits,
- 2 circuits of hot water,
- heat storage tank (buffer),
- solar system.

### 1.2 Contents

1. Expansion module CAN I/O MC-1
2. Terminal strips
3. Power cord
4. Communication cable CAN/1,5

## 1.3 Safety precautions

### **Warning – risk of electric shock!**

- Read this operation manual carefully and thoroughly before using the unit.
- Keep this operation manual and refer to it whenever you work with this unit in the future.
- Apply all the rules and heed all the warnings included in the unit operation manual.
- Make sure that the unit is not damaged. In case of any doubts, do not use the unit and contact the supplier.
- In case of any doubts concerning the safe operation of the unit, contact the supplier.
- Pay special attention to all warning signs on the unit casing and its package.
- Use the unit as intended.
- The unit is not a toy. Do not allow children to play with it.
- Under no circumstances children should be allowed to play with any parts of the package of the unit.
- Access to small parts such as clamping screws or bolts should be secured against children. Such elements may be delivered with the unit and may result in choking when swallowed by a child.
- Do not make any mechanical or electrical changes to the unit. Such changes may cause the unit to malfunction and fail to meet the relevant standards, leading to an adverse impact on the performance of the unit.
- Do not insert any objects into the unit through openings (e.g. ventilation grills), as this may cause short circuiting, electric shock, fire or damage to the unit.
- Do not allow water, humidity or dust to enter the unit, as this may cause short circuiting, electric shock, fire or damage to the unit.
- Provide adequate ventilation of the unit, do not cover or block the ventilation grills, and ensure that there is free flow of air around the unit.
- The unit should be installed indoors unless it is adapted for outdoor operation.
- Do not expose the unit to mechanical impacts and vibrations.
- When connecting the unit to power supply, make sure that the parameters of the supply network are within the unit's operating range.
- All electrical connections must be as shown in the electrical assembly drawings and must comply with national and/or local regulations concerning electrical connections.

# 1 General information

---

- This unit contains no parts that may be replaced by the user. All maintenance work except for cleaning, fuse replacement (when the unit is de-energized), and function setting, should be performed by an authorized service provider.
- Before doing any maintenance work, you must cut off the power supply to the unit.
- Do not clean the casing of the unit with petrol, solvents or any other chemicals that may damage the casing of the unit. Using a soft cloth is recommended.

## 1.4 Disposal of old equipment

This electronic equipment is made of materials which are partly recyclable. Therefore, when the equipment has reached the end of its service life, take it to an electrical and electronic equipment recycling centre or to the manufacturer. The equipment must not be disposed of with other household waste.



## 2 Connecting to the system

---

## 2 Connecting to the system

### 2.1 General requirements

Read this operation manual carefully and thoroughly before you start using the unit.

The person installing the unit should have sufficient technical experience.

Copper wire connections should be designed to work in temperatures of up to +75°C .

All connections made must be as shown in the electrical wiring assembly drawings and must be compliant with national and/or local regulations concerning electrical connections.



**WARNING !!!** *Wiring must be done with the device disconnected from the mains. Connections should be exercised by a person possessing adequate permissions in this area.*



**WARNING !!!** *The device must be connected to a separate electrical circuit equipped with an appropriately sized circuit breaker and residual current circuit breaker.*

### 2.2 Location

The unit is intended for indoor installation only. After selecting the location, make sure that it meets the following requirements:

1. The location must be free from excessive humidity and from flammable or corrosive vapours.
2. The unit must not be installed near high power electrical equipment, electrical machines or welding equipment.
3. The temperature in the location must not exceed 60°C and should not be lower than 0°C. Humidity should be within the range from 5% to 95%, with no vapour condensation taking place.

## 2 Connecting to the system

### 2.3 Assembly

The unit is suitable for mounting on standard 35mm DIN rail.

All dimensions are in millimetres.

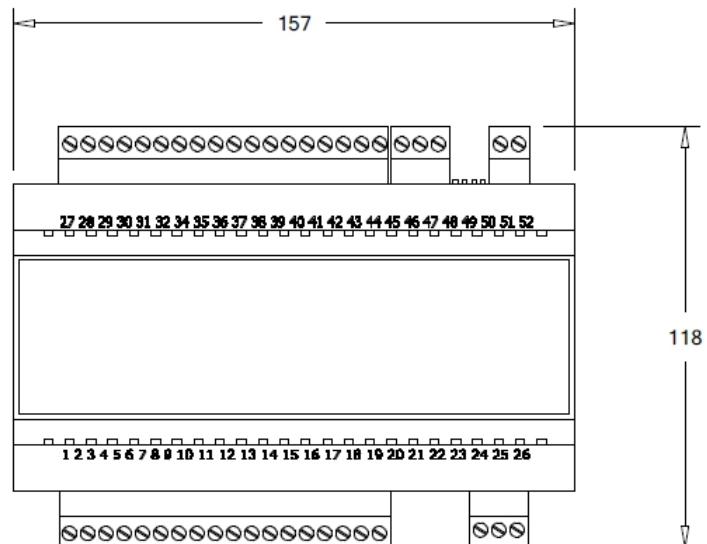
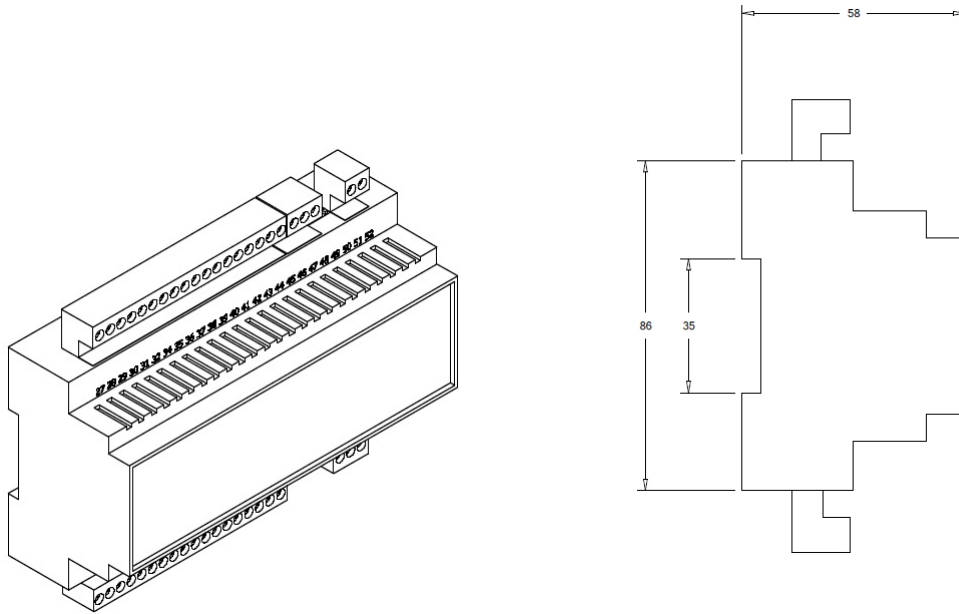



## 2 Connecting to the system

### 2.4 Connecting

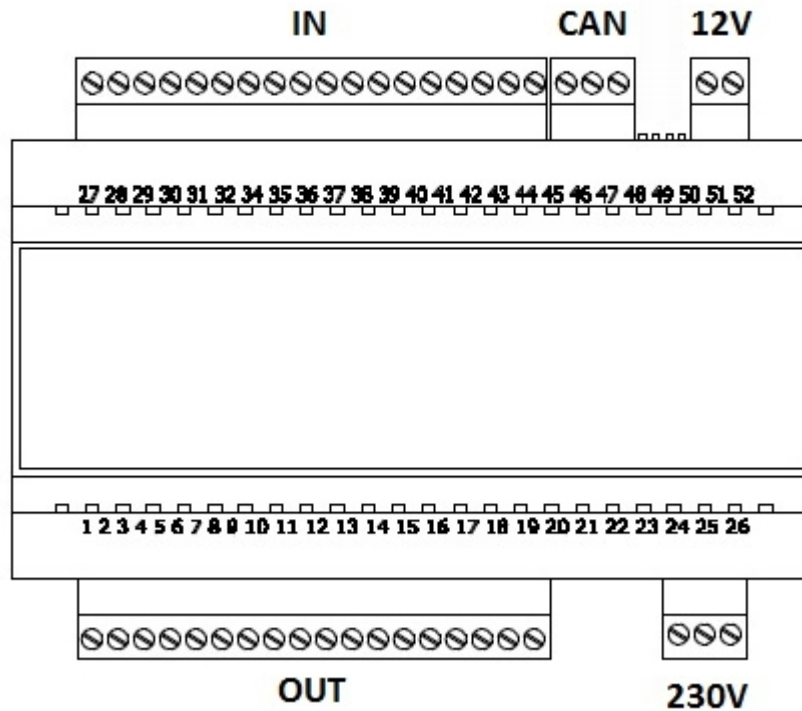

Description:
<b>IN</b> – inputs
<b>OUT</b> – outputs
<b>CAN</b> – CAN bus
<b>12V</b> – power output +12V
<b>230V</b> – power module

## 2 Connecting to the system

### 2.4.1 Power

The power supply is 230V.

The following chart illustrates how to connect the power cord.

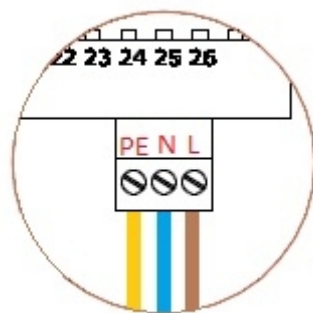

Description:

L – phase vein (brown)

N – neutral vein (blue)

PE – protective vein (yellow-green)

### 2.4.2 CAN

For connections to CAN bus should be only used cable **LiYCY 2x0,25**.

Only this type of cable gives proper work of equipment.

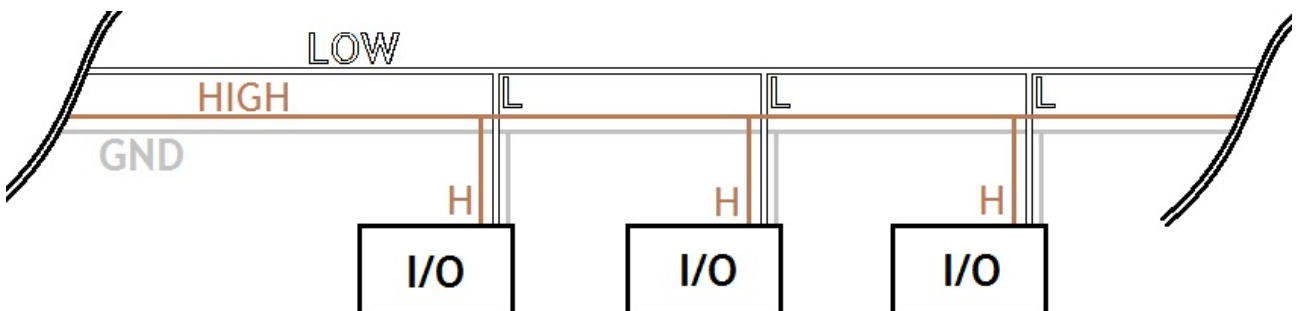

Description:

**L** – LOW line (white)

**H** – HIGH line (brown)

**GND** – ground (gray)

## 2 Connecting to the system

### 2.4.3 Output power +12V

Is used to power other peripherals that require +12 V.

This makes it easy connection to additional devices, reducing the need for another power sources.

### 2.5 Modules addressing

To broadcast the address of the module is used DIP switch.

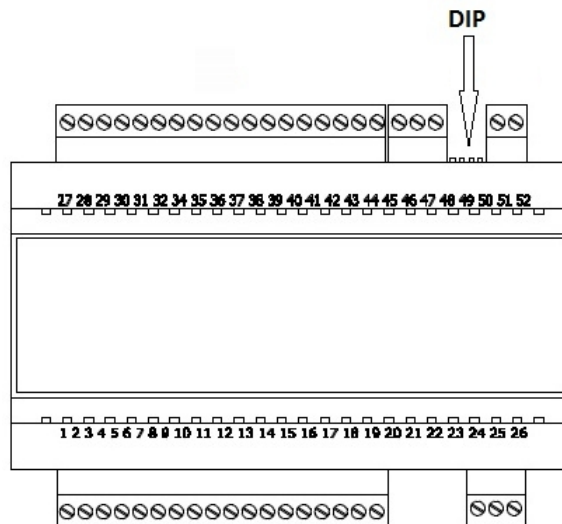

**The whole system can be only one module for each address.**

Total value of switches with numbers 1, 2, 3 in the ON position sets the unit number, eg the module with the address 7 must be accompanied by switches with values 4, 2, 1.

Total of these numbers designate the address, in this case it will be a module number 7.

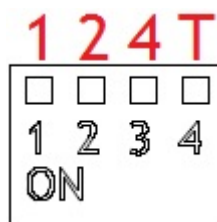

## 2 Connecting to the system

The switch should be set according to the following table.

DIP switch No (value)			Module No
1(1)	2(2)	3(4)	
OFF	OFF	OFF	Module 0
ON	OFF	OFF	Module 1
OFF	ON	OFF	Module 2
ON	ON	OFF	Module 3
OFF	OFF	ON	Module 4
ON	OFF	ON	Module 5
OFF	ON	ON	Module 6
ON	ON	ON	Module 7

DIP switch with number 4 (**T**) is used to set the terminator.

The whole system **must be** 2 terminators:

1. As standard includes a main unit, that is controller IGNEO line.
2. Must be manually set on the I/O module.

Terminator should be turn on the module farthest from the MASTER unit.

Is activated by switching to the **ON** position switch marked with the letter **T**.

The following chart shows how to set terminators in the system.

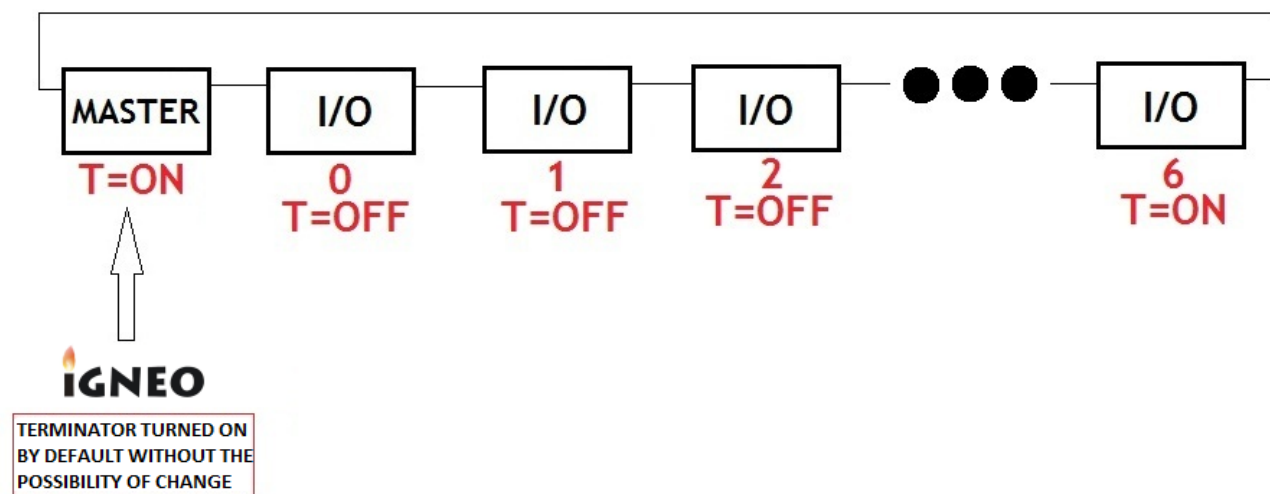

### 3 Circuits diagrams

#### 3.1 System 1

This is the basic type of system. Connects up to 16 separate heating circuits and circuit hot water.

The first circuit is operated by a control unit that is controller IGNEO. Other be fully controlled by the expansion modules with addresses 0-4. Each expansion module controls three heating circuits with a circulating pump and mixer.

In addition, the module number 0 reads outdoor temperature from the sensor mounted outside the building.

To build this system need:

- new line IGNEO controller
- outdoor temperature sensor CTZ-01
- 5 expansion modules CAN I/O, 1 for every 3 heating circuits
- 16 room temperature sensors CTP-01 or newer CTP-02, 1 for each heating circuit.

# 3 Circuits diagrams

System No 1

**IMPORTANT!**  
Scheme does not include all elements of the system.

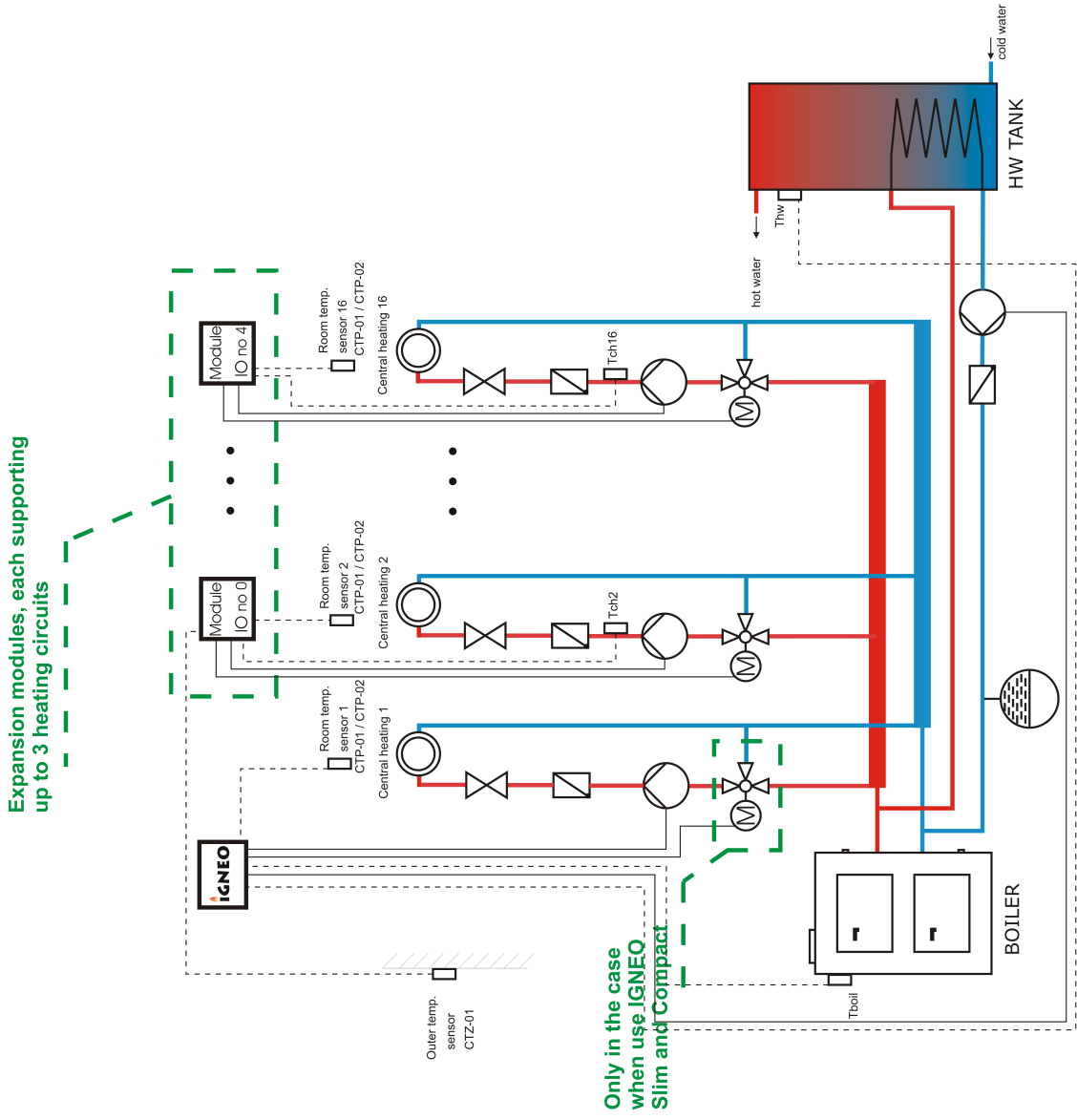

### 3.2 System 2

Same as the previous system, can connect up to 16 separate circuits heating and hot water. In addition, has been extended to support solar panels.

First circuit is operated by a control unit that is controller IGNEO. Other fully controlled by the expansion modules with addresses 0-4. Each module enlargement is controlled by three heating circuits with a circulating pump and mixer. Module 0 of the outside mounted sensor reads the outdoor temperature.

Collectors are supervised by the module I/O address 5.

To build this system need:

- new line IGNEO controller
- outdoor temperature sensor CTZ-01
- 6 expansion modules CAN I/O, modules number 0-4 for heating circuits and module number 5 for solar collectors
- 16 room temperature sensors CTP-01 or newer CTP-02, 1 for each heating circuit.

# 3 Circuits diagrams

System No 2

**IMPORTANT!**  
Scheme does not include all elements of the system.

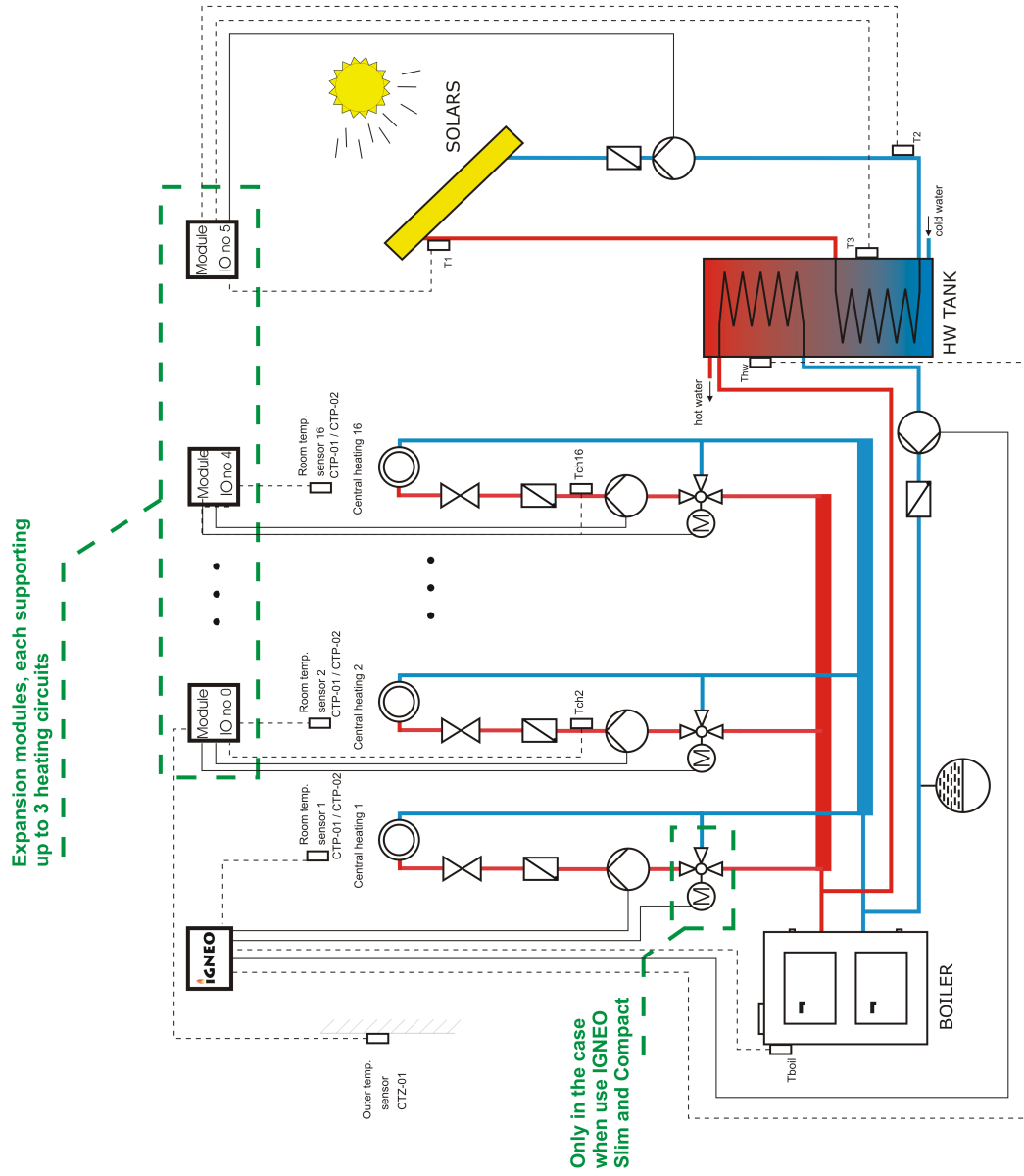



### 3.3 System 3

This is again an extensive system No. 1. Allows to connect 16 separate heating circuits and circuit hot water. In this scheme also uses the heat buffer.

First circuit is operated by a control unit that is controller IGNEO. Other fully controlled by the expansion modules with addresses 0-4. Each module enlargement controls three heating circuits with a circulating pump and mixer. Module 0 of the outside mounted sensor reads the outdoor temperature.

Module No. 5 controls charging pump heat buffer. Also operates a boiler with a pump-mixing with mixer, whose task is to maintain a minimum temperature of water returning to the boiler.

To build this system need:

- new line IGNEO controller
- outdoor temperature sensor CTZ-01
- 6 expansion modules CAN I/O, modules number 0-4 for heating circuits and module number 5 for heat buffer
- 16 room temperature sensors CTP-01 or newer CTP-02, 1 for each heating circuit.

# 3 Circuits diagrams

System No 3

**IMPORTANT!**  
Scheme does not include all elements of the system.

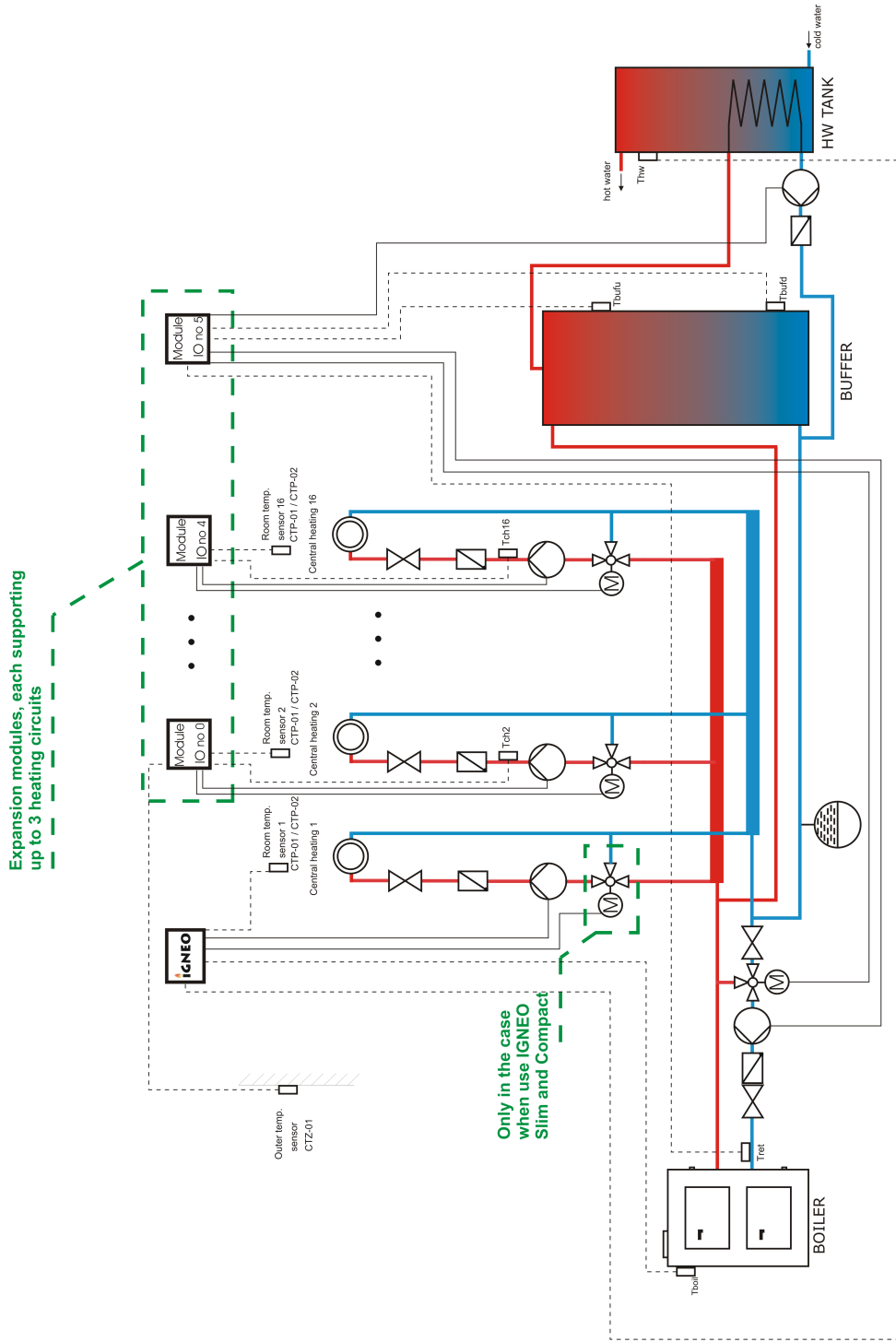

### 3.4 System 4

This system is a combination of past schemes. Allows to connect 16 separate heating circuits and circuit hot water. The system was extended to solar collectors and heat buffer.

First circuit is operated by a control unit that is controller IGNEO. Other fully controlled by the expansion modules with addresses 0-4. Each module enlargement controls three heating circuits with a circulating pump and mixer. Module 0 of the outside mounted sensor reads the outdoor temperature.

Module No. 5 manages the charging pump heat buffer. Also controls the boiler pump-mixing with a mixer, whose task is to maintain a minimum temperature of water returning to the boiler. In addition, it controls solar collectors.

To build this system need:

- new line IGNEO controller
- outdoor temperature sensor CTZ-01
- 6 expansion modules CAN I/O, modules number 0-4 for heating circuits and module number 5 for heat buffer and solar collectors
- 16 room temperature sensors CTP-01 or newer CTP-02, 1 for each heating circuit.

# 3 Circuits diagrams

System No 4

**IMPORTANT!**  
Scheme does not include all elements of the system.

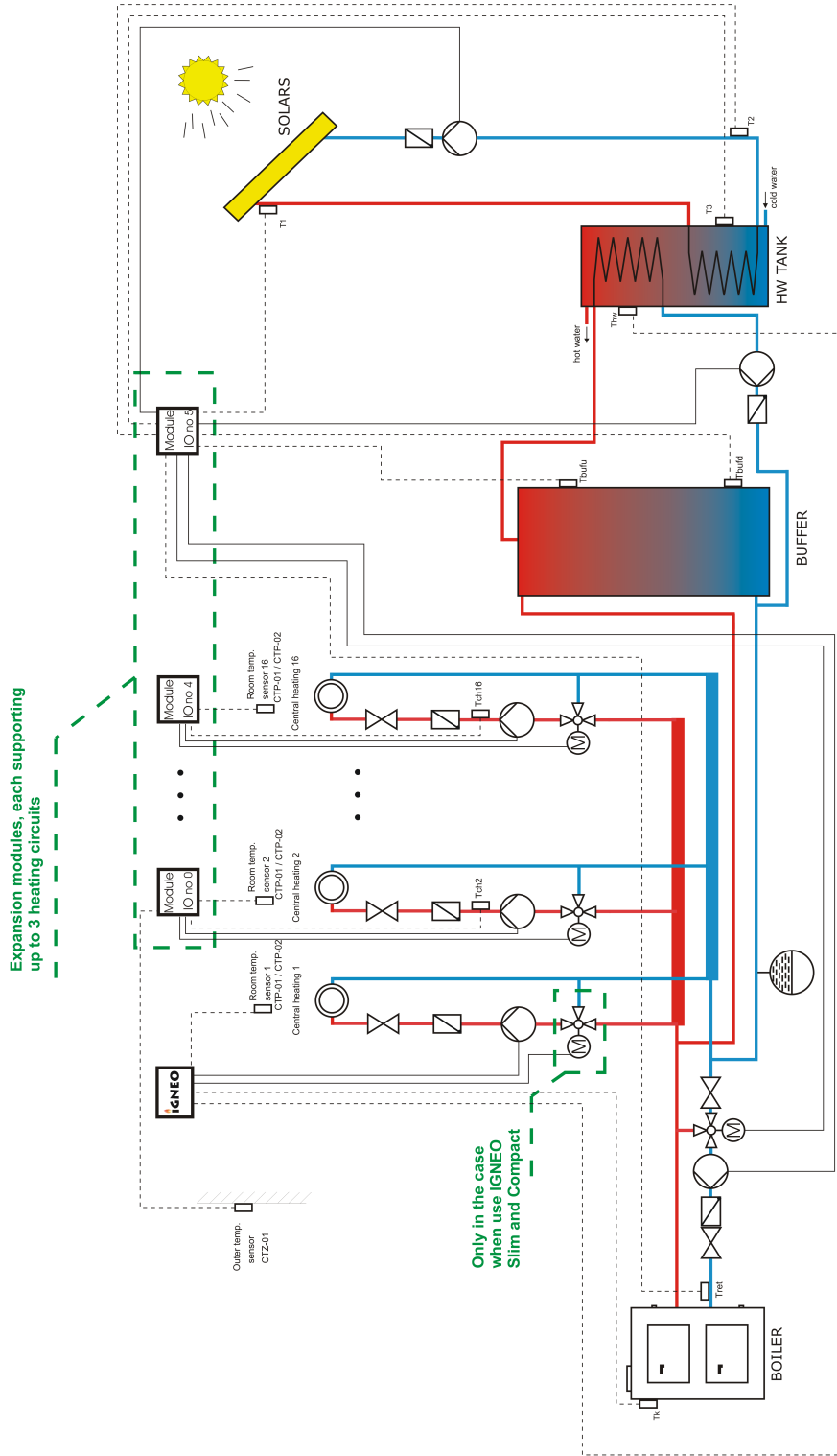

### 3.5 System 5

This layout is almost identical to the previous system. The only difference is an integrated hot water tank with heat buffer. Allows to connect 16 separate heating circuits and circuit hot water.

First circuit is operated by a control unit that is controller IGNEO. Other fully controlled by the expansion modules with addresses 0-4. Each module enlargement controls three heating circuits with a circulating pump and mixer. Module 0 of the outside mounted sensor reads the outdoor temperature.

Module No. 5 manages the charging pump heat buffer. Also controls the boiler pump-mixing with a mixer, whose task is to maintain a minimum temperature of water returning to the boiler. In addition, it controls solar collectors.

To build this system need:

- new line IGNEO controller
- outdoor temperature sensor CTZ-01
- 6 expansion modules CAN I/O, modules number 0-4 for heating circuits and module number 5 for heat buffer and solar collectors
- 16 room temperature sensors CTP-01 or newer CTP-02, 1 for each heating circuit.

# 3 Circuits diagrams

System No 5

**IMPORTANT!**  
Scheme does not include all elements of the system.

Expansion modules, each supporting up to 3 heating circuits

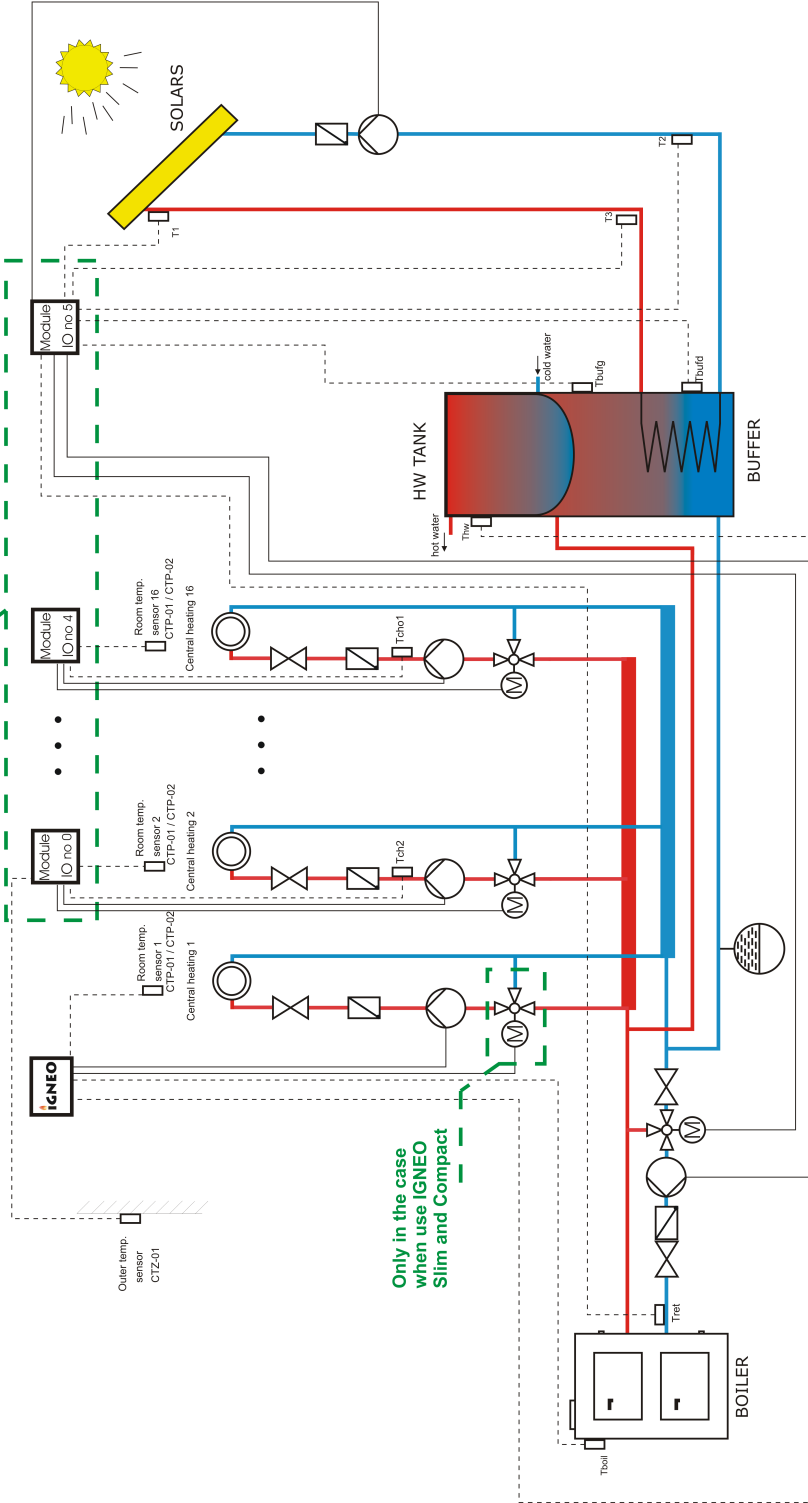

# 4 Description of input and output modules

## 4 Description of input and output modules

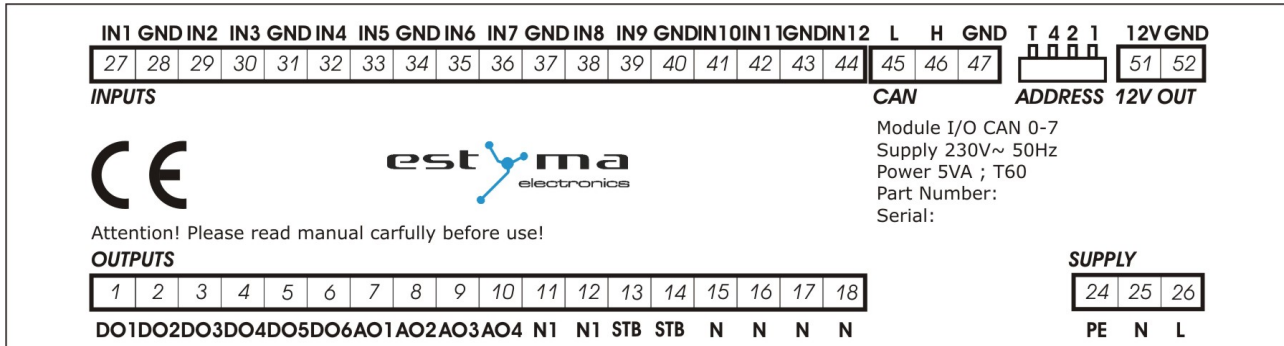

### 4.1 Module 0 - circuits CH 2-4

Module 0 – circuits CH 2, 3, 4			
No	Input description	No	Output description
27	AIN1 – CH temperature sensor circuit 2 (Tch <sub>2</sub> )	1	DO1 – opening mixer circuit CH 2 (Mope <sub>2</sub> )
28	GND	2	DO2 – closing mixer circuit CH 2 (Mclo <sub>2</sub> )
29	AIN2 – room temperature sensor circuit 2 (Troom <sub>2</sub> )	3	DO3 – opening mixer circuit CH 3 (Mope <sub>3</sub> )
30	AIN3 – CH temperature sensor circuit 3 (Tch <sub>3</sub> )	4	DO4 – closing mixer circuit CH 3 (Mclo <sub>3</sub> )
31	GND	5	DO5 – opening mixer circuit CH 4 (Mope <sub>4</sub> )
32	AIN4 – room temperature sensor circuit 3 (Troom <sub>3</sub> )	6	DO6 – closing mixer circuit CH 4 (Mclo <sub>4</sub> )
33	AIN5 – CH temperature sensor circuit 4 (Tch <sub>4</sub> )	7	AO1 – pump output circuit CH 2
34	GND	8	AO2 – pump output circuit CH 3
35	AIN6 – room temperature sensor circuit 4 (Troom <sub>4</sub> )	9	AO3 – pump output circuit CH 4
36	AIN7 – not connected	10	AO4 – not connected
37	GND		
38	AIN8 – not connected		
39	AIN9 – not connected		
40	GND		
41	AIN10 – not connected		
42	AIN11 Tout – outside temperature sensor (only in module No. 0, common to all CH circuits)		
43	GND		
44	AIN12 – not connected		

## 4 Description of input and output modules

---

### 4.2 Module 1 - circuits CH 5-7

Module 1 – circuits CH 5, 6, 7			
No	Input description	No	Output description
27	AIN1 – CH temperature sensor circuit 5 (Tch <sub>5</sub> )	1	DO1 – opening mixer circuit CH 5 (Mope <sub>5</sub> )
28	GND	2	DO2 – closing mixer circuit CH 5 (Mclo <sub>5</sub> )
29	AIN2 – room temperature sensor circuit 5 (Troom <sub>5</sub> )	3	DO3 – opening mixer circuit CH 6 (Mope <sub>6</sub> )
30	AIN3 – CH temperature sensor circuit 6 (Tch <sub>6</sub> )	4	DO4 – closing mixer circuit CH 6 (Mclo <sub>6</sub> )
31	GND	5	DO5 – opening mixer circuit CH 7 (Mope <sub>7</sub> )
32	AIN4 – room temperature sensor circuit 6 (Troom <sub>6</sub> )	6	DO6 – closing mixer circuit CH 7 (Mclo <sub>7</sub> )
33	AIN5 – CH temperature sensor circuit 7 (Tch <sub>7</sub> )	7	AO1 – pump output circuit CH 5
34	GND	8	AO2 – pump output circuit CH 6
35	AIN6 – room temperature sensor circuit 7 (Troom <sub>7</sub> )	9	AO3 – pump output circuit CH 7
36	AIN7 – not connected	10	AO4 – not connected
37	GND		
38	AIN8 – not connected		
39	AIN9 – not connected		
40	GND		
41	AIN10 – not connected		
42	AIN11 – not connected		
43	GND		
44	AIN12 – not connected		



## 4 Description of input and output modules

### 4.3 Module 2 – circuits CH 8-10

Module 2 – circuits CH 8, 9, 10			
No	Input description	No	Output description
27	AIN1 – CH temperature sensor circuit 8 (Tch <sub>8</sub> )	1	DO1 – opening mixer circuit CH 8 (Mope <sub>8</sub> )
28	GND	2	DO2 – closing mixer circuit CH 8 (Mclo <sub>8</sub> )
29	AIN2 – room temperature sensor circuit 8 (Troom <sub>8</sub> )	3	DO3 – opening mixer circuit CH 9 (Mope <sub>9</sub> )
30	AIN3 – CH temperature sensor circuit 9 (Tch <sub>9</sub> )	4	DO4 – closing mixer circuit CH 9 (Mclo <sub>9</sub> )
31	GND	5	DO5 – opening mixer circuit CH 10 (Mope <sub>10</sub> )
32	AIN4 – room temperature sensor circuit 9 (Troom <sub>9</sub> )	6	DO6 – closing mixer circuit CH 10 (Mclo <sub>10</sub> )
33	AIN5 – CH temperature sensor circuit 10 (Tch <sub>10</sub> )	7	AO1 – pump output circuit CH 8
34	GND	8	AO2 – pump output circuit CH 9
35	AIN6 – room temperature sensor circuit 10 (Troom <sub>10</sub> )	9	AO3 – pump output circuit CH 10
36	AIN7 – not connected	10	AO4 – not connected
37	GND		
38	AIN8 – not connected		
39	AIN9 – not connected		
40	GND		
41	AIN10 – not connected		
42	AIN11 – not connected		
43	GND		
44	AIN12 – not connected		

## 4 Description of input and output modules

---

### 4.4 Module 3 – circuits CH 11-13

Module 3 – circuits CH 11, 12, 13			
No	Input description	No	Output description
27	AIN1 – CH temperature sensor circuit 11 (Tch <sub>11</sub> )	1	DO1 – opening mixer circuit CH 11 (Mope <sub>11</sub> )
28	GND	2	DO2 – closing mixer circuit CH 11 (Mclo <sub>11</sub> )
29	AIN2 – room temperature sensor circuit 11 (Troom <sub>11</sub> )	3	DO3 – opening mixer circuit CH 12 (Mope <sub>12</sub> )
30	AIN3 – CH temperature sensor circuit 12 (Tch <sub>12</sub> )	4	DO4 – closing mixer circuit CH 12 (Mclo <sub>12</sub> )
31	GND	5	DO5 – opening mixer circuit CH 13 (Mope <sub>13</sub> )
32	AIN4 – room temperature sensor circuit 12 (Troom <sub>12</sub> )	6	DO6 – closing mixer circuit CH 13 (Mclo <sub>13</sub> )
33	AIN5 – CH temperature sensor circuit 13 (Tch <sub>13</sub> )	7	AO1 – pump output circuit CH 11
34	GND	8	AO2 – pump output circuit CH 12
35	AIN6 – room temperature sensor circuit 13 (Troom <sub>13</sub> )	9	AO3 – pump output circuit CH 13
36	AIN7 – not connected	10	AO4 – not connected
37	GND		
38	AIN8 – not connected		
39	AIN9 – not connected		
40	GND		
41	AIN10 – not connected		
42	AIN11 – not connected		
43	GND		
44	AIN12 – not connected		

## 4 Description of input and output modules

### 4.5 Module 4 – circuits CH 14-16

Module 4 – circuits CH 14, 15, 16			
No	Input description	No	Output description
27	AIN1 – CH temperature sensor circuit 14 (Tch <sub>14</sub> )	1	DO1 – opening mixer circuit CH 14 (Mope <sub>14</sub> )
28	GND	2	DO2 – closing mixer circuit CH 14 (Mclo <sub>14</sub> )
29	AIN2 – room temperature sensor circuit 14 (Troom <sub>14</sub> )	3	DO3 – opening mixer circuit CH 15 (Mope <sub>15</sub> )
30	AIN3 – CH temperature sensor circuit 15 (Tch <sub>15</sub> )	4	DO4 – closing mixer circuit CH 15 (Mclo <sub>15</sub> )
31	GND	5	DO5 – opening mixer circuit CH 16 (Mope <sub>16</sub> )
32	AIN4 – room temperature sensor circuit 15 (Troom <sub>15</sub> )	6	DO6 – closing mixer circuit CH 16 (Mclo <sub>16</sub> )
33	AIN5 – CH temperature sensor circuit 16 (Tch <sub>16</sub> )	7	AO1 – pump output circuit CH 14
34	GND	8	AO2 – pump output circuit CH 15
35	AIN6 – room temperature sensor circuit 16 (Troom <sub>16</sub> )	9	AO3 – pump output circuit CH 16
36	AIN7 – not connected	10	AO4 – not connected
37	GND		
38	AIN8 – not connected		
39	AIN9 – not connected		
40	GND		
41	AIN10 – not connected		
42	AIN11 – not connected		
43	GND		
44	AIN12 – not connected		

## 4 Description of input and output modules

---

### 4.6 Module 5 – circuits HW 2, buffer, solar collectors

Module 5 – circuits HW 2, buffer , solar collectors			
No	Input description	No	Output description
27	AIN1 – HW temperature sensor circuit 2 (Thw <sub>2</sub> )	1	DO1 – opening mixer return (increase reception from boiler)
28	GND	2	DO2 – closing mixer return (decreases reception from boiler, increases return temperature)
29	AIN2 – upper temperature buffer sensor (Tbufu)	3	DO3 – not connected
30	AIN3 – lower temperature buffer sensor (Tbufd)	4	DO4 – not connected
31	GND	5	DO5 – solar mixer L
32	AIN4 – boiler return temperature sensor	6	DO6 – solar mixer R
33	AIN5 – not connected	7	AO1 – circulating pump output HW circuit 2
34	GND	8	AO2 – boiler pump output (buffer)
35	AIN6 – solar sensor T1	9	AO3 – not connected
36	AIN7 – solar sensor T2	10	AO4 – solar output 1
37	GND		
38	AIN8 – solar sensor T3		
39	AIN9 – solar sensor T4		
40	GND		
41	AIN10 – not connected		
42	AIN11 – not connected		
43	GND		
44	AIN12 – not connected		

---

CE

Manufactured by:

Estyma electronics  
al. Lipowa 4  
11-500 Giżycko  
POLAND

tel. +48 87 429 86 75  
fax +48 87 429 86 75  
biuro@estyma.pl

**[www.estyma.pl](http://www.estyma.pl)**

